

# SPECIFICATION

## PRATIKA 310 EV PRO

### TECHNICAL DATA

- Noiseless
- Ladder pack is extendable in 7 sections
- **New CTE patented box-type profile ensuring high stiffness for a greater load reliability excellent stability and manoeuvrability**
- Safety end of stroke microswitch
- Safety at travel limits
- Total absence of pollution
- **40% maintenance cost reduction**
- Working speed up to 52m per min.
- Powered by maintenance free gel batteries
- Liquid crystal display and hydraulic controls
- Hexagonal beam with articulated teflon foot
- Fifth wheel with locking ring
- **Electric motor with energy regeneration while trailer is descending**
- Many tool boxes
- Spacious deck
- **Use of the elevator without support with lateral loading/unloading**

### PERFORMANCE

Stowed ladder pack length	5,4 m
Extended ladder pack length	31 m
Maximum height	2,91 m
Overall length	5,66 m
Working angle	35°/90°
Maximum capacity	300 kg
Trolley speed	52 m/min
Total weight	3,5 t

Mounted on Nissan Cabstar

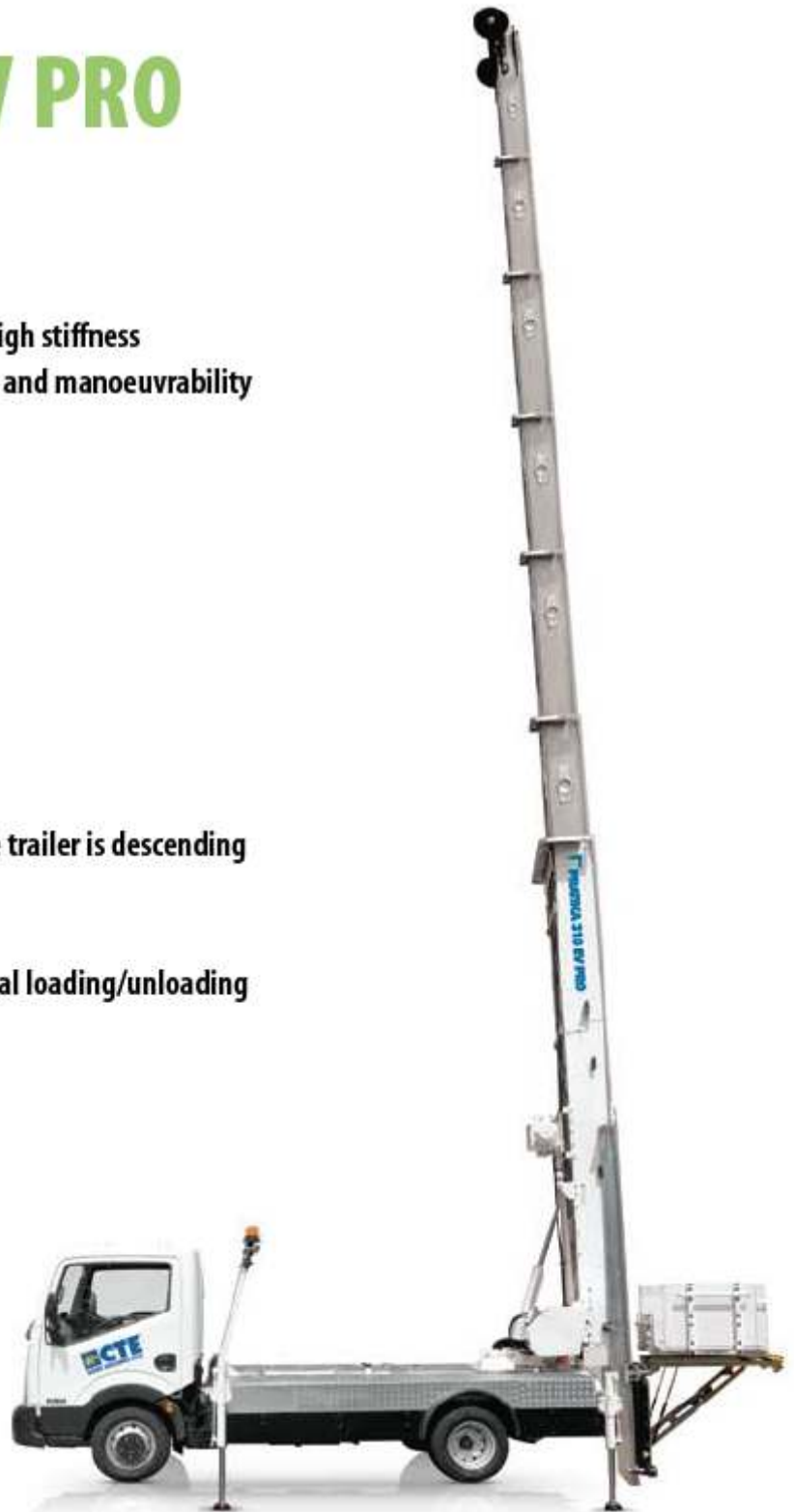

## LADDER DIMENSIONS

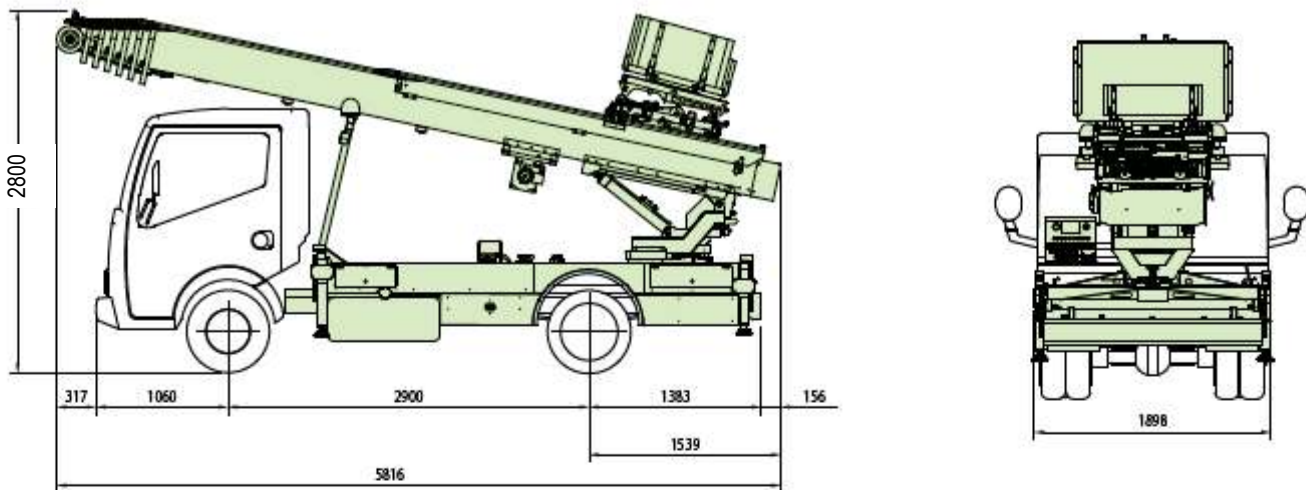

## KEY POINTS



CTES.p.A. | [www.ctelift.com](http://www.ctelift.com)

Sales Office Dolo (Ve) - [dolo@ctelift.com](mailto:dolo@ctelift.com)  
 ph. +39 041 51.00.130 - fax +39 041 41.38.44  
 Headquarter Rovereto (Tn) - [info@ctelift.com](mailto:info@ctelift.com)  
 ph. +39 0464 48.50.50 - fax +39 0464 48.50.99  
 Milano Branch S. Giuliano Milanese (Mi) - [milano@ctelift.com](mailto:milano@ctelift.com)  
 ph. +39 02 98.81.100 - fax +39 02 98.28.20.96  
 Bertinoro Branch & Factory (FC) - [bertinoro@ctelift.com](mailto:bertinoro@ctelift.com)  
 ph. +39 0543 44.88.30 - fax +39 0543 44.83.43

**PRATIKA**