

TRACTOR T4000

ELECTRICPORTER

FANTOZZI

moving safe. at work



General features and advantages

FANTOZZI T4000 tractor is suitable to tow up to 4000 Kg. inside and outside the factory. The T4000 electric tractor assures the maximum driving comfort together with safe driving and production increase.

Intensive use

The high numbers of scheduled working handlings and meanwhile the unexpected emergencies and precision, need reliable tools always versatile and available to carry-out continuous work granting high quality levels.

Slim and strong FANTOZZI T4000 is suitable to drive into small and complex ways; working proof resistant inside the stocking area and factory on flat floors.

Increase on productivity

FANTOZZI T4000 tractor answers the modern concept of logistic, goods handling and people's transport which require more and more skilled and dedicated working instruments suitable to reach the best compromise between working time, working quality & precision, and operator's safety & satisfaction.

During handling of unpacked goods or single pieces - without pallets or loading units - FANTOZZI T4000 produces a significant increase in productivity, it means much more work arranged shortly and saving of human resources.

Driving comfort

FANTOZZI T4000 has comfortable driving position, easy access to the operating control unit, limited height of the platform and comfortable adjustable seat: these allow the operator to drive longtime on safety and correct position, in accordance with ergonomic standards.

Accessories such as goods-holder or objects support make the daily operations easier; whereas the front and rear lights, side lights and covering cab make the vehicle safer.



Maximum safety for operator, goods and environment
The modern concept of safety is not only limited to the operator but to the complete "system": operator, goods, environment.

FANTOZZI T4000 is studied in accordance with current regulations as for accident-prevention, limited vibrations, industrial health, common protection etc, but mainly thinking on ethic responsibility and reliability as for working satisfaction and appreciation of human resources.

Technical / manufacturing features

Motor

Equipped with 3000W motor - Loading capacity 900 Kg. - Towing capacity 4000 Kg.



Differential gear

Differential gear complete with shafts. Shafts have supports connected to the aluminium body in order to make the structure safer.

Chassis

Strong structure made of Fe37 with black embossing non-scratch epoxy painting. The structure reinforcements guarantee the maximum vehicle's reliability.

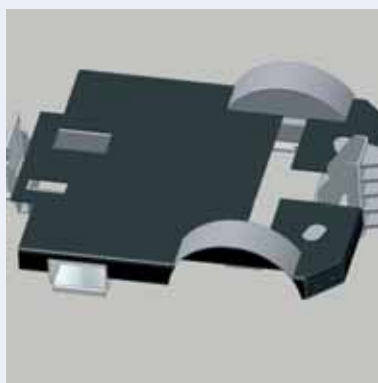

Electronic control unit

The electronic control unit allows the speed-braking-acceleration adjustments: these parameters customize the use of FANTOZZI T4000.

Battery

The vehicle is equipped with one traction battery 24V 480Ah (8 hours endurance).



Pedal accelerator

FANTOZZI T4000 is equipped with two acceleration pedals: one for the forward driving and the other for the backward driving. The pedals are placed under the steering wheel and can be operated by the right foot.

Service brake

Service brake pedal is operated by the left foot. The motor has a gradual counterbrake and finally the service brake enters automatically.



Emergency button

The red button placed near the driver's seat allows the instant stop and limits the risk of accident inside and outside the factory.



Towing hook

The FANTOZZI T4000 is equipped with adjustable towing hook: it helps the operator during every kind of towing operations.



Adjustable steering wheel

The lever placed on the left side of the steering wheel allows the adjustment in accordance with operator's comfort.



Steering wheel

Simple, easy, essential, the steering wheel has:

- Control knob
- Lights switch
- Charge indicator display
- Warning buzzer
- Side lights lever
- Adjustable steering-wheel lever
- Starting key



Side lights

Side lights are not only in the rear position of the vehicle but also in left/right sides: this makes the vehicle safer during driving operations inside and outside the factory.



Optionals

Rain-proof cab
Iron made structure with black embossing painting, the cab is complete with left & right mirrors and PVC covering.



Roll bar
Tubular iron structure with black embossing painting.



Technical features

VDI 2198

Features	1.1	Manufacturer		Fantozzi
	1.2	Model		T4000
	1.3	Traction		Electric
	1.4	Type of driving		Seated on board
	1.5	Loading capacity	Q (t)	40
Weights	1.9	Wheel axis	y (mm)	970
	2.1	Weight including batteries	Kg	890
Wheels / structure	3.1	Tyres (superelastic, pneumatic..)		SE
	3.2	Front wheel dimensions		5.00 - 8
	3.3	Rear wheel dimensions		5.00 - 8
	3.5	Front wheel number (x = traction)		2
	3.5.1	Rear wheel number (x = traction)		2
	3.6	Front wheel track	b ₁₀ (mm)	780
	3.7	Rear wheel track	b ₁₁ (mm)	850
Basic dimensions	4.7	Operator's protection height (cab)	h ₆ (mm)	1060
	4.8	Operator's seat height	h ₇ (mm)	860
	4.12	Towing hook height	h ₁₀ (mm)	250
	4.13	Platform height (without loading)	h ₁₁ (mm)	360
	*****	Clearance	h ₁₁ (mm)	270
	4.16	Loading platform length	l ₃ (mm)	330
	4.17	Loading platform width	b ₉ (mm)	950
	4.19	Total length	l ₁ (mm)	2130
	4.21	Total width	b ₁ (mm)	950
		Working aisle width	(mm)	1150
		Intersecting aisle width	(mm)	1900
		Minimum rack width between 2 working aisles	(mm)	800
		90° Turning radius	(Wa mm)	1530
* Performances	5.1	Driving speed with full loading	km/h	8
	5.1.1	Driving speed without loading	km/h	10
	5.8	Max. grade with full loading	%	5
	5.10	Service brake		Electromechanical + hydraulic
	5.11	Parking brake		Electromechanical
		Emergency brake		Electromechanical
		Driver detection sensor		Mechanical
Electric motor	6.1	Traction motor - capacity KB 60 min	kW	3
	6.3	Battery		24V 480Ah
	6.4	Battery tension	U V	24V
	6.4.1	Battery capacity	K 5 Ah	480Ah
	6.5	Battery weight	Kg	390
Others	8.1	Kind of transmission	Diff.	1:15,5
	8.4	Average noise for the operator	dB (A)	< 70
	8.5	Towing hook		Mechanical
	8.6	Steering gear		Wheel
	Vibration to the operator		/	

* the performances refer to the vehicle in perfect conditions, with charged battery and regular motor maintenance

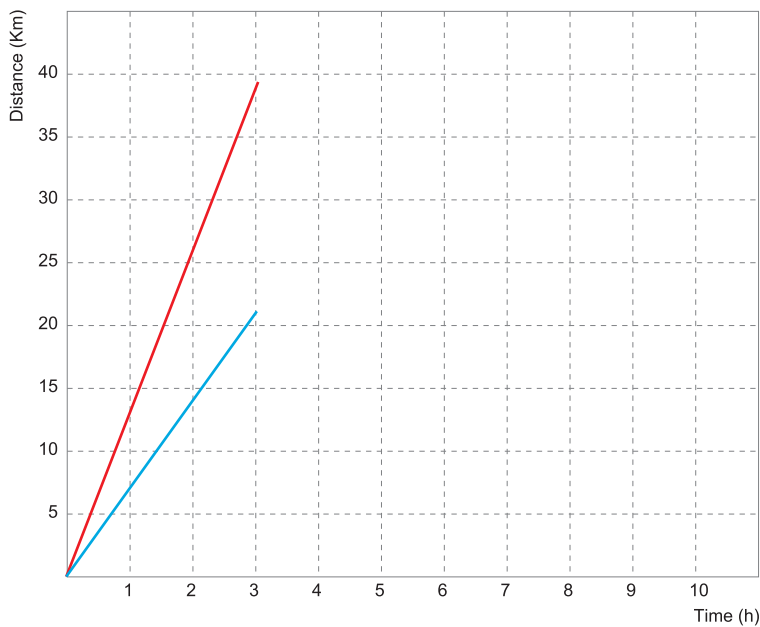
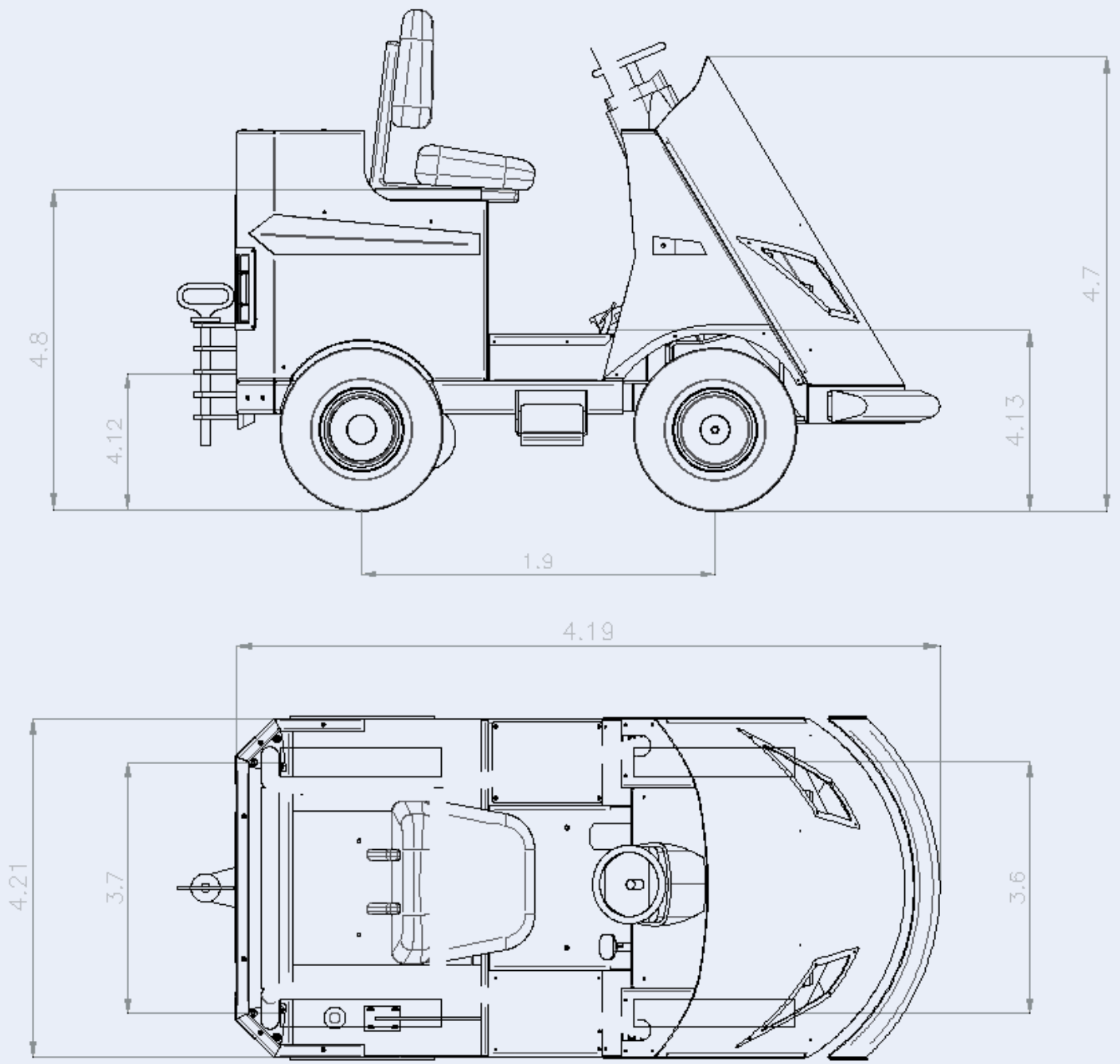

Easy and safe movement production increased

A tractor doubly necessary.
The FANTOZZI T4000 is the top range vehicle. The compact dimensions allow the vehicle to drive inside the factory, in the same time the strong structure, special tyres and complete lighting system allow the operator to drive also outside the factory.

Safe working. You can! You must!

ELECTRICPORTER RANGE 2007



TRACTORS



PLATFORMS



SCOOTERS



HOSPITAL



EC CERTIFICATION



IN ACCORDANCE
WITH 626 LAW



1000 Kg.
MAXIMUM LOADING



80 cm.
WAY WIDTH



2500 Kg.
TOWING CAPACITY

FANTOZZI

moving safe. at work

Fantozzi Electric Carts S.r.l.
Via Rosa Luxemburg, 24
42010 Rio Saliceto (RE) - Italy
Tel. +39 0522 647192
Fax +39 0522 699479
info@fantozzi.com
sales@fantozzi.com
www.fantozzi.com