

TELESCOPIC TRUCK MOUNTED PLATFORMS



SPECIFICATION

B-LIFT 187 PRO (version with A-frame outriggers)

- Telescopic boom (3 elements) (main boom + 2 telescopic extensions) • 540° non continuous turret rotation on bearing turntable • Proportional electrohydraulic controls with simultaneous manoeuvres (ergonomic joysticks) • Engine start/stop control from basket • Anti slip aluminium flatbed decking • Aluminium basket • System to automatically limit the outreach depending on the weight in the basket • 60° Right + 60° Left electric rotating basket • Automatic basket levelling by hydraulic parallelogram • N° 4 hydraulic outriggers with ground pressure sensors • 230 V AC CE Electric socket in the basket • Buzzer when PTO is coupled with disconnected hand brake • Hour meter • N° 1 flashing beacon • Ground control station with display

PERFORMANCE

Working height	18 m	Capacity	80/200/250 kg
Platform height	16 m	Basket dim.	1400x700x1100 mm
Working outreach	10,9/8/7,1 m	GVW minimum	3,5 t

DIMENSIONS

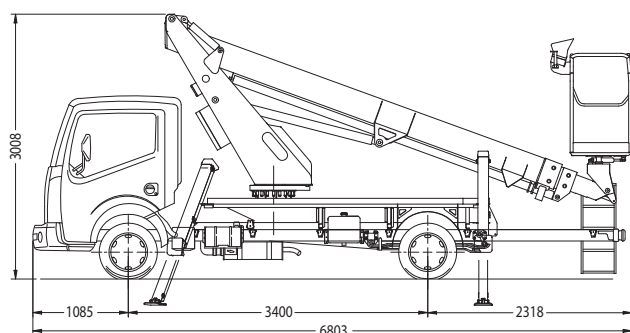

OUTRIGGER FOOTPRINT

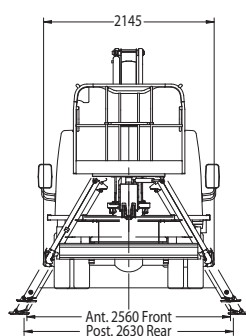

WORKING ENVELOPE

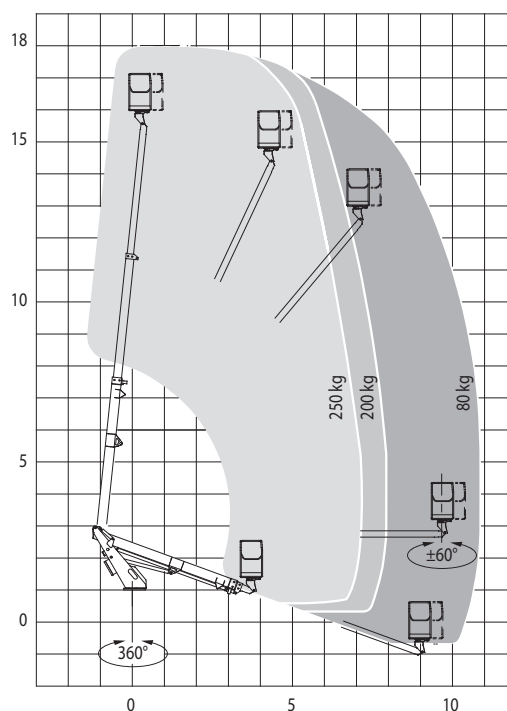

The EASY KIT version is available for assembly on trucks with a g.v.w. of more than 3,5 ton, outside the CE countries.

Product specifications are subject to change without notice or obligation. Technical features and drawings in this brochure are for illustrative purposes only. B187PROA - ed. 10/09

ADVERTENDO.COM™ We know how.



Branches: Rovereto, Dolo and S. Giuliano Milanese

CTE S.p.A. | www.ctelift.com

Sales Office Dolo (Ve) - dolo@ctelift.com
 ph. +39 041 51.00.130 - fax +39 041 41.38.44
 Headquarter Rovereto (Tn) - info@ctelift.com
 ph. +39 0464 48.50.50 - fax +39 0464 48.50.99
 Milano Branch S. Giuliano Milanese (Mi) - milano@ctelift.com
 ph. +39 02 98.81.100 - fax +39 02 98.28.20.96
 Bertinoro Branch & Factory (FC) - bertinoro@ctelift.com
 ph. +39 0543 44.88.30 - fax +39 0543 44.83.43

