

SPECIFICATION

B-LIFT 201 PRO

(version with A-frame outriggers)

TECHNICAL DATA

- Telescopic boom (4 elements) (main boom + 3 telescopic extensions)
- 540° non continuous turret rotation on bearing turntable
- Proportional electrohydraulic controls with simultaneous manoeuvres (ergonomic joysticks)
- Engine Start/Stop control from basket
- Anti slip aluminium flatbed decking
- Aluminium basket
- System to automatically limit the outreach depending on the weight in the basket
- 60° Right + 60° Left electric rotating basket
- Automatic basket levelling by hydraulic parallelogram
- N° 4 hydraulic outriggers with ground pressure sensors
- 230 V AC CE electric socket in the basket
- Buzzer when PTO is coupled with disconnected hand brake
- Hour meter
- N° 1 flashing beacon
- Ground control station with display

PERFORMANCE

Working height	20 m
Platform height	18 m
Working outreach	10/7,3/6,6 m
Capacity	80/200/250 kg
Basket dim.	1400x700x1100 mm
GVW minimum	3,5 t

The EASY KIT version is available for assembly on trucks with a g.v.w. of more than 3,5 ton, outside the CE countries.



DIMENSIONS - OUTRIGGER FOOTPRINT

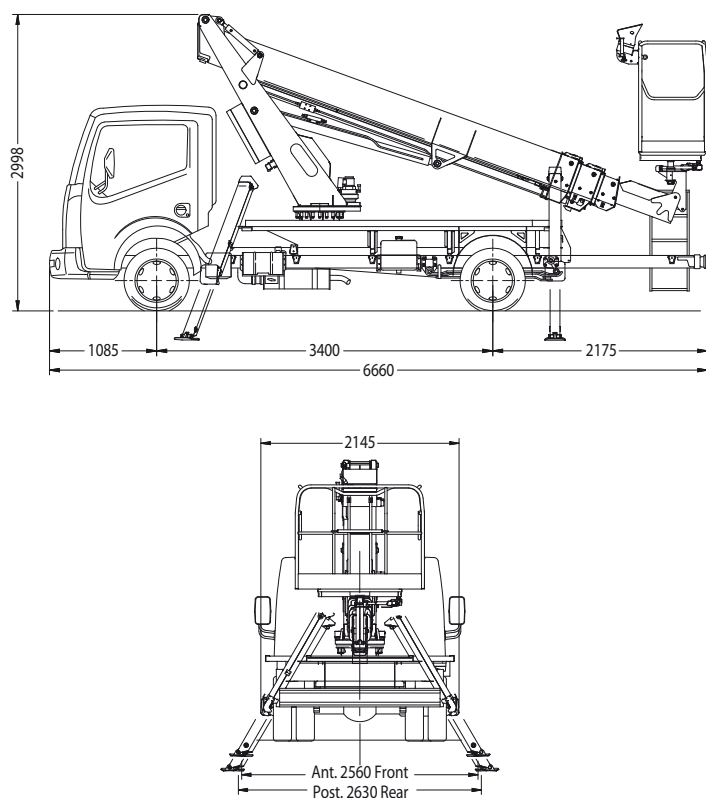

WORKING ENVELOPE

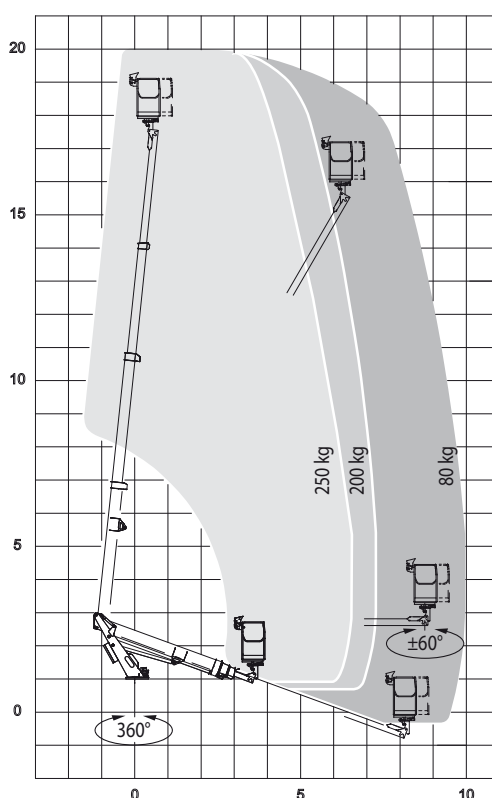

KEY POINTS

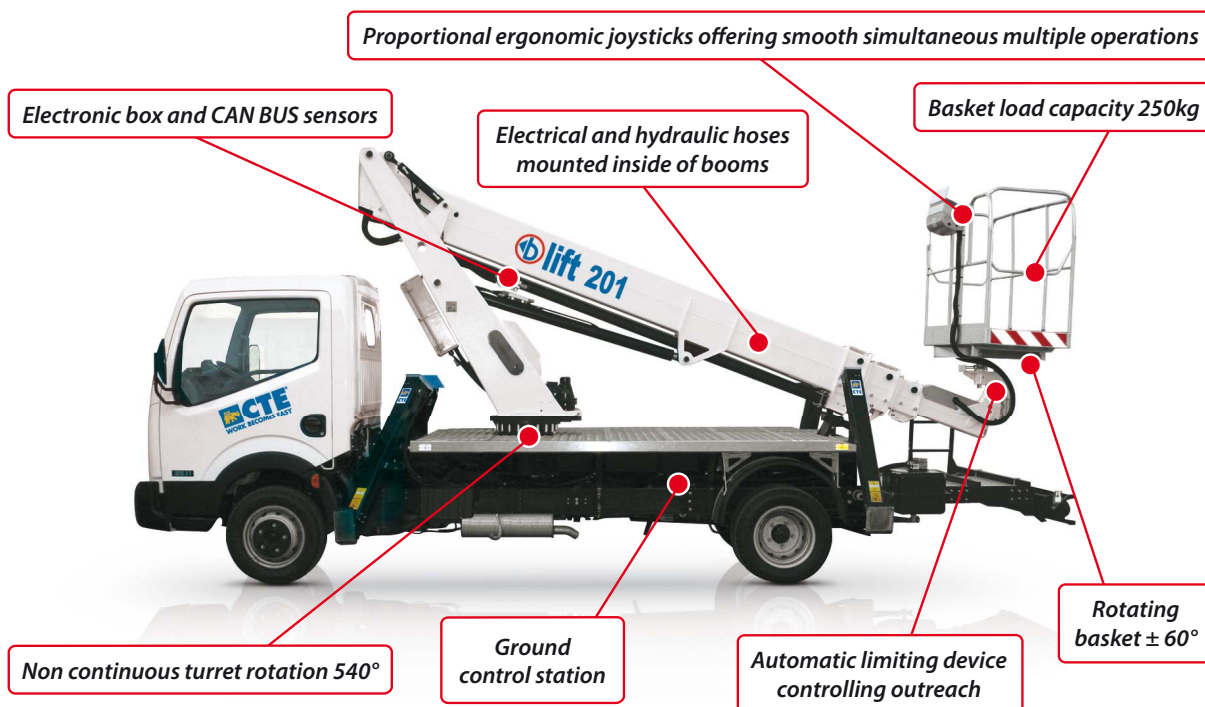

CTE S.p.A. | www.ctelift.com

Sales Office Dolo (Ve) - dolo@ctelift.com
 ph. +39 041 51.00.130 - fax +39 041 41.38.44
 Headquarter Rovereto (Tn) - info@ctelift.com
 ph. +39 0464 48.50.50 - fax +39 0464 48.50.99
 Milano Branch S. Giuliano Milanese (Mi) - milano@ctelift.com
 ph. +39 02 98.81.100 - fax +39 02 98.28.20.96
 Bertinoro Branch & Factory (FC) - bertinoro@ctelift.com
 ph. +39 0543 44.88.30 - fax +39 0543 44.83.43



Product specifications are subject to change without notice or obligation. Technical features and drawings in this brochure are for illustrative purposes only. B201R0A - ed. 12/09



Branches: Rovereto, Dolo and S. Giuliano Milanese