

# SPECIFICATION

## **B-LIFT 201 PRO**

**(version with H-frame outriggers)**

### **TECHNICAL DATA**

- Telescopic boom (4 elements) (main boom + 3 telescopic extensions)
- 540° non continuous turret rotation on bearing turntable
- Proportional electrohydraulic controls with simultaneous manoeuvres (ergonomic joysticks)
- Engine start/stop control from basket
- Vehicle cab anticollision devices
- Anti slip aluminium flatbed decking
- Aluminium basket
- System to automatically limit the outreach depending on the weight in the basket
- 60° Right + 60° Left electric rotating basket
- Automatic basket levelling by hydraulic parallelogram
- Automatic working range delimitation (180°) with outriggers extended only on one side (left/right)
- Working range with outriggers not extended (narrow jacking)
- N° 4 hydraulic outriggers with ground pressure sensors
- 230 V AC CE Electric socket in the basket
- Buzzer when PTO is coupled with disconnected hand brake
- Hour meter
- N° 1 flashing beacon
- Ground control station with display

### **PERFORMANCE**

Working height	20 m
Platform height	18 m
Working outreach	12,9/8,8 m
Capacity	80/250 kg
Basket dim.	1400x700x1100 mm
GVW minimum	3,5 t



## DIMENSIONS - OUTRIGGER FOOTPRINT

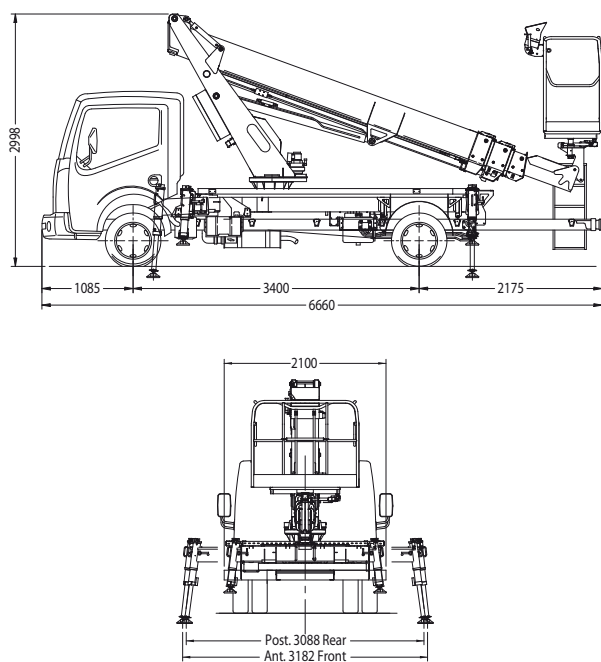

## WORKING ENVELOPE

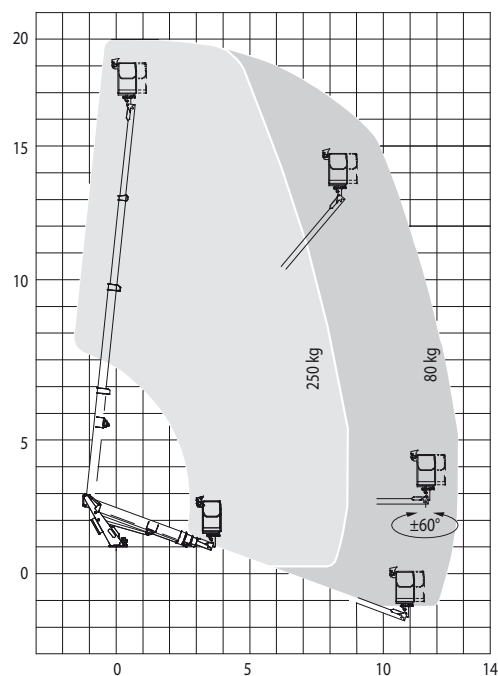

## KEYPOINTS

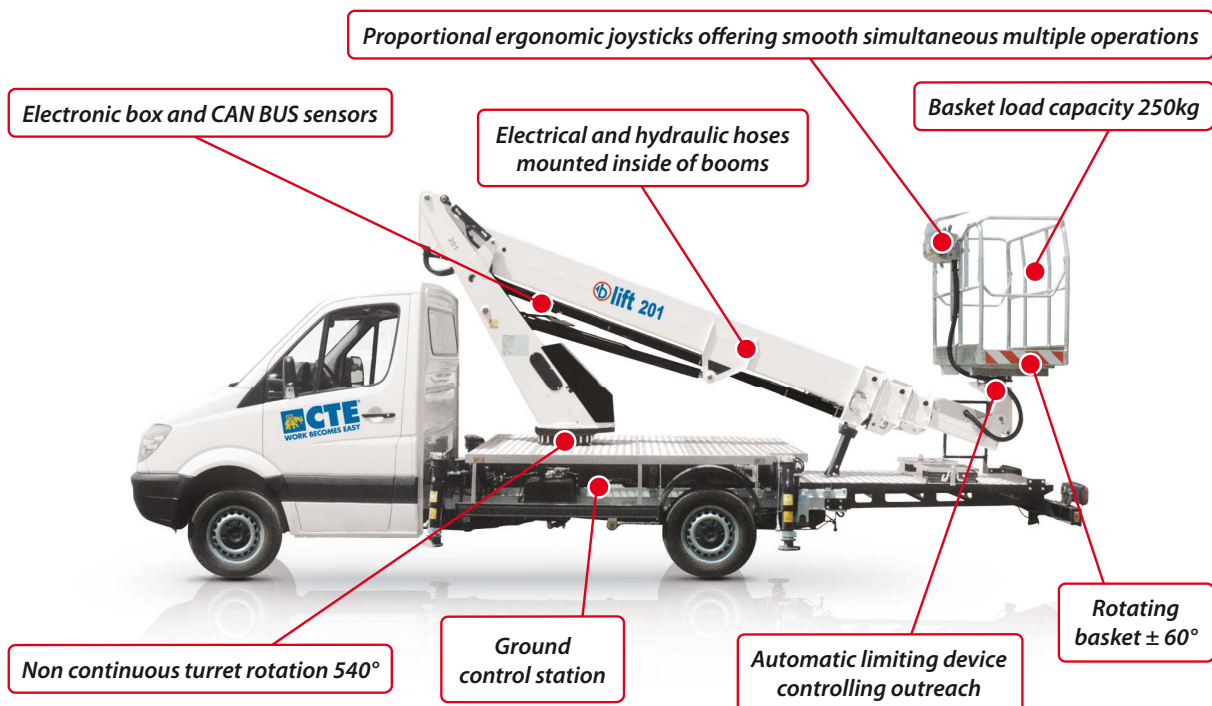

CTE S.p.A. | [www.ctelift.com](http://www.ctelift.com)

Sales Office Dolo (Ve) - [dolo@ctelift.com](mailto:dolo@ctelift.com)  
 ph. +39 041 51.00.130 - fax +39 041 41.38.44  
 Headquarter Rovereto (Tn) - [info@ctelift.com](mailto:info@ctelift.com)  
 ph. +39 0464 48.50.50 - fax +39 0464 48.50.99  
 Milano Branch S. Giuliano Milanese (Mi) - [milano@ctelift.com](mailto:milano@ctelift.com)  
 ph. +39 02 98.81.100 - fax +39 02 98.28.20.96  
 Bertinoro Branch & Factory (FC) - [bertinoro@ctelift.com](mailto:bertinoro@ctelift.com)  
 ph. +39 0543 44.88.30 - fax +39 0543 44.83.43

