

TECHNICAL DATA

- Double pantograph + telescopic boom (main boom + two extensions)+ jib
- Sigma boom movement enabled by connecting rods
- 360° continuous turret rotation on bearing turntable
- Proportional, electrohydraulic controls in basket
- Engine start and stop controls from basket
- Anti-slip, aluminium flatbed decking with tool tray walls
- Aluminium basket
- 65° right + 65° left hydraulic basket rotation
- Automatic hydraulically actioned basket levelling
- Basket load sensing device
- 4 hydraulic outriggers with ground pressure sensors
- Hydraulic system operated by vehicle's PTO
- 230 V AC CE electrical socket in the basket
- 1 flashing beacon
- Buzzer indicating PTO engaged
- Hour meter
- Standard boom colours blue (RAL 5017) or white (RAL 9010)
- CE certified

DIMENSIONS

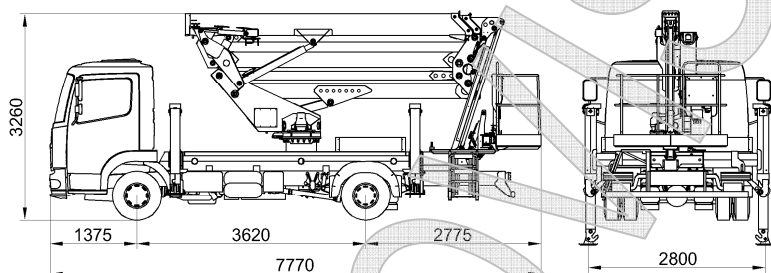

WORKING ENVELOPE

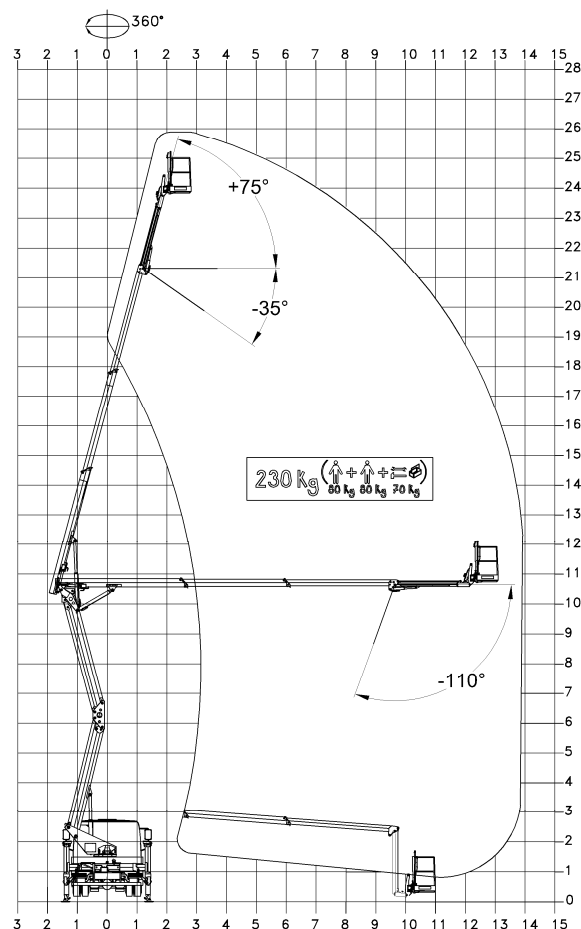

PERFORMANCE

Working height	26m
Platform height	24m
Working outreach	14m
Capacity	230 kg
Basket dimensions	1800x700x1100 mm
GVW minimum	7,5t

CTE S.p.A. | www.ctelift.com

Sales Office Dolo (Ve) - dolo@ctelift.com
 ph. +39 041 51.00.130 - fax +39 041 41.38.44
 Headquarter Rovereto (Tn) - info@ctelift.com
 ph. +39 0464 48.50.50 - fax +39 0464 48.50.99
 Milano Branch S. Giuliano Milanese (MI) - milano@ctelift.com
 ph. +39 02 98.81.100 - fax +39 02 98.28.20.96
 Bertinoro Branch & Factory (FC) - bertinoro@ctelift.com
 ph. +39 0543 44.88.30 - fax +39 0543 44.83.43

