

ARTICULATED TRUCK MOUNTED PLATFORMS



SPECIFICATION ZED 32 JH

- Double pantograph + telescopic arm with triple extension + jib
- Sigma boom movement enabled by connecting rods
- 360° continuous turret rotation on bearing turntable
- Proportional, electrohydraulic controls in basket and ground
- Engine start and stop controls from basket and ground
- Anti slip flatbed decking
- Aluminium basket
- 90° Right + 90° Left hydraulic basket rotation
- Automatic hydraulically actioned basket levelling
- Basket load sensing device
- N° 4 "H" frame hydraulic outriggers with ground pressure contact sensors
- Hydraulic system operated by vehicle's PTO
- 230 V AC EC electrical socket in the basket
- 1 flashing beacon
- Buzzer indicating PTO engaged
- Hour meter
- Standard boom colours blue (RAL 5017) or white (RAL 9010)
- CE certified

PLATFORM DIMENSIONS

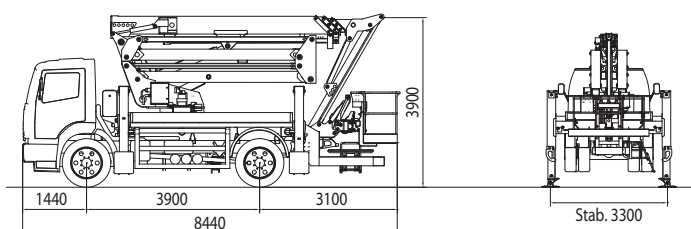

WORKING ENVELOPE

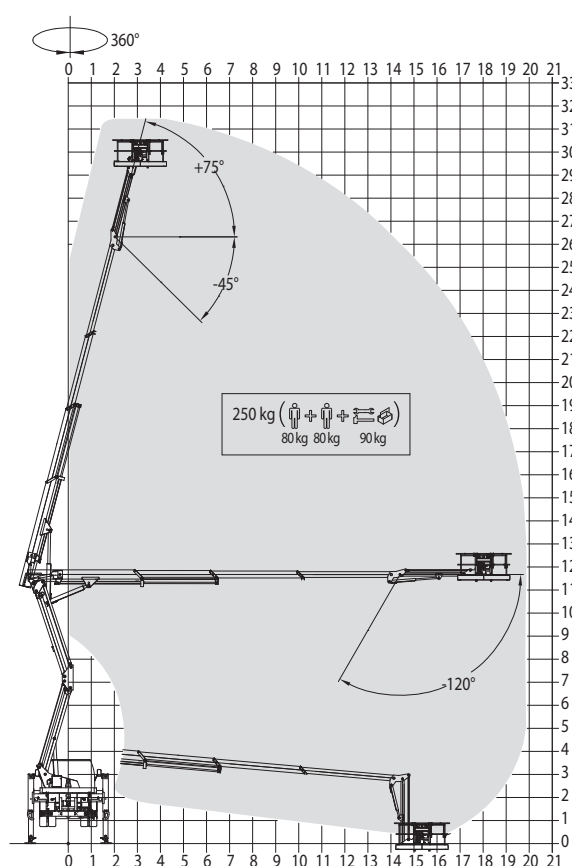

OUTRIGGER FOOTPRINT

- a.** Outriggers left side open
- b.** All outriggers open
- c.** Outriggers right side open

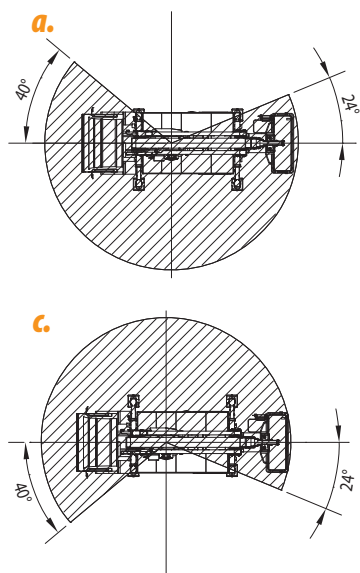

PERFORMANCE

Working height	31,5 m	Capacity	250 kg
Platform height	29,5 m	Basket dim.	2400x800x1100 mm
Working outreach	19,8 m	GVW minimum	18 t

CTE S.p.A. | www.ctelift.com

Sales Office Dolo (Ve) - dolo@ctelift.com
 ph. +39 041 51.00.130 - fax +39 041 41.38.44
 Headquarter Rovereto (Tn) - info@ctelift.com
 ph. +39 0464 48.50.50 - fax +39 0464 48.50.99
 Milano Branch S. Giuliano Milanese (Mi) - milano@ctelift.com
 ph. +39 02 98.81.100 - fax +39 02 98.28.20.96
 Bertinoro Branch & Factory (FC) - bertinoro@ctelift.com
 ph. +39 0543 44.88.30 - fax +39 0543 44.83.43

