

ALFA M evo

Manual movement and lifting for maximum comfort and simplicity when handling loads that are not particularly heavy.



ALFA SMALL 12V evo

Version with manual movement and electro-hydraulic elevation for quick lifting operations without operator's physical effort. Single-stage lifting mast for lift heights between 800 and 1600 mm.



ALFA 12V evo

Semi-electric version with two-stage mast for lift heights up to 3.5 meters.

Features in detail: _____



ADJUSTABLE FORKS:

Forks can be manually adjusted in the fork holder plate; a simple operation that allows using the same truck for loads that have different overall dimensions.



DRIVING HANDLES:

Side handles to assure easy maneuvering and positioning of the truck with manual movements.



MANUAL LIFTING (ALFA M evo):

Quick lift hand pump with lowering control installed in the same pump to facilitate a quick execution of every operation.



ELECTRO-HYDRAULIC LIFTING (12V versions):

Lifting and lowering control switches are installed in a protective casing. An Emergency Stop switch cuts the power supply.



ALFA M evo

| model | | 55/08 | 105/08 | 25/16 | 55/16 | 105/16 |
|-------|----|---------|---------|---------|---------|---------|
| Q | Kg | 500 | 1000 | 250 | 500 | 1000 |
| C | mm | 600 | 600 | 400 | 400 | 400 |
| I | mm | 1150 | 1150 | 800 | 800 | 800 |
| L | mm | 1730 | 1730 | 1210 | 1380 | 1380 |
| X | mm | 400 | 400 | 130 | 200 | 200 |
| Y | mm | 1270 | 1270 | 1015 | 1120 | 1120 |
| L2 | mm | 580 | 580 | 405 | 580 | 580 |
| M | mm | 200/800 | 240/800 | 200/800 | 200/800 | 240/800 |
| N | mm | 100 | 120 | 100 | 100 | 120 |
| h1 | mm | 1230 | 1230 | 1990 | 1990 | 1990 |
| h2 | mm | 800 | 800 | 1600 | 1600 | 1600 |
| h3 | mm | 800 | 800 | 1600 | 1600 | 1600 |
| h4 | mm | 1240 | 1240 | 1990 | 2000 | 2000 |
| B | mm | 800 | 800 | 800 | 800 | 800 |
| E | mm | 520 | 530 | 540 | 520 | 530 |
| F | mm | 405 | 350 | 415 | 405 | 350 |
| S | mm | 50 | 55 | 42 | 50 | 55 |
| WA | mm | 1320 | 1320 | 1050 | 1135 | 1135 |

STANDARD EQUIPMENT

- High free lift (simplex mast) • Lifting by fast manual pump (without load) • Descent by lever • Adjustable forks length 800 mm (1150 mm for 800 mm lifting height) • Parking Brake • Polyurethane single roller • Polyamide wheels with polyurethane covering • Safety components • Manual Traction

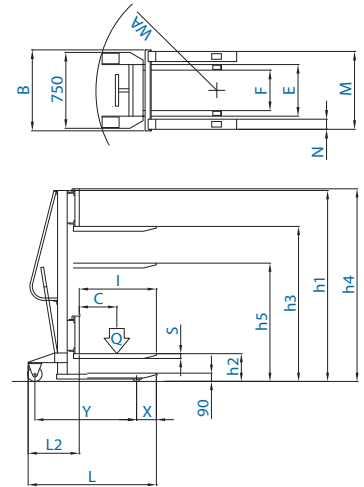

ALFA SMALL 12V evo

| model | | 55/08 | 105/08 | 55/16 | 105/16 |
|-------|----|---------|---------|---------|---------|
| Q | Kg | 500 | 1000 | 500 | 1000 |
| C | mm | 600 | 600 | 400 | 400 |
| I | mm | 1150 | 1150 | 800 | 800 |
| L | mm | 1730 | 1730 | 1380 | 1380 |
| X | mm | 400 | 400 | 200 | 200 |
| Y | mm | 1270 | 1270 | 1120 | 1120 |
| L2 | mm | 580 | 580 | 580 | 580 |
| M | mm | 200/800 | 240/800 | 200/800 | 240/800 |
| N | mm | 100 | 120 | 100 | 120 |
| h1 | mm | 1230 | 1230 | 1990 | 1990 |
| h2 | mm | 800 | 800 | 1600 | 1600 |
| h3 | mm | 800 | 800 | 1600 | 1600 |
| h4 | mm | 1240 | 1240 | 2000 | 2000 |
| B | mm | 800 | 800 | 800 | 800 |
| E | mm | 520 | 520 | 520 | 530 |
| F | mm | 405 | 405 | 405 | 350 |
| S | mm | 50 | 55 | 50 | 55 |
| WA | mm | 1320 | 1320 | 1135 | 1135 |

STANDARD EQUIPMENT

- High free lift (simplex mast) • Built-in electronic battery charger 12V 10A with microprocessor • Forks control by push-buttons • Adjustable forks length 800 mm (1150 mm for 800 mm lifting height) • Parking Brake • Polyurethane single roller • Polyamide wheels with polyurethane covering • Safety components • Manual Traction • Battery 12V 80 AH

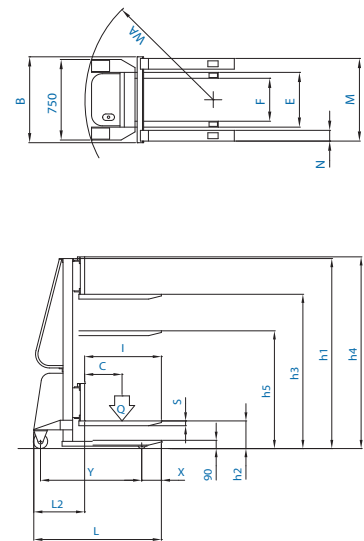

ALFA 12V evo

| model | | 55/25 | 105/25 | 55/30 | 105/30 | 55/35 | 105/35 |
|-------|----|---------|---------|---------|---------|---------|---------|
| Q | Kg | 500 | 1000 | 500 | 1000 | 500 | 1000 |
| C | mm | 400 | 400 | 400 | 400 | 400 | 400 |
| I | mm | 800 | 800 | 800 | 800 | 800 | 800 |
| L | mm | 1390 | 1410 | 1390 | 1410 | 1390 | 1410 |
| X | mm | 200 | 200 | 200 | 200 | 200 | 200 |
| Y | mm | 1135 | 1155 | 1135 | 1155 | 1135 | 1155 |
| L2 | mm | 585 | 605 | 585 | 605 | 585 | 605 |
| M | mm | 240/800 | 240/800 | 240/800 | 240/800 | 240/800 | 240/800 |
| N | mm | 120 | 120 | 120 | 120 | 120 | 120 |
| h1 | mm | 1750 | 1750 | 1990 | 1990 | 2250 | 2250 |
| h2 | mm | 200 | 200 | 200 | 200 | / | / |
| h3 | mm | 2500 | 2500 | 3000 | 3000 | 3500 | 3500 |
| h4 | mm | 2920 | 2920 | 3420 | 3420 | 3920 | 3920 |
| B | mm | 800 | 800 | 800 | 800 | 800 | 800 |
| E | mm | 525 | 525 | 525 | 525 | 525 | 525 |
| F | mm | 355 | 355 | 355 | 355 | 355 | 355 |
| S | mm | 50 | 55 | 50 | 55 | 50 | 55 |
| WA | mm | 1200 | 1220 | 1200 | 1220 | 1200 | 1220 |

STANDARD EQUIPMENT

- Free lift 200 mm (excluded lifting height mm. 3500) • Built-in electronic battery charger 12V 15A with microprocessor • Forks control by push-buttons • Adjustable forks length 800 mm • Electric end stroke • Parking Brake • Polyurethane single roller • Polyamide wheels with polyurethane covering • Safety components • Manual Traction • Battery 12V 155 AH

