

FIXED MANUAL RAMP WITH GAS ASSISTANCE

Model CR-GAS



Thanks to gas strut servo-assistance, fixed manual ramps type CR-GAS can be longer than CR, thus overcoming BIGGER DIFFERENCES OF HEIGHT (preferably positive ones) WITH SIMPLE AND EFFICIENT MOVIMENTATION through a rigid side handle

Optional:

- **45-90° beveled lip on last 120mm**
- **L-shaped screwable plate 150x250mm for fixing**
- **Flat lip for small wheeled vehicles, ONLY FOR 0 OR NEGATIVE DIFFERENCES OF HEIGHT**
- **Side protection frame with bumpers (see photo)**

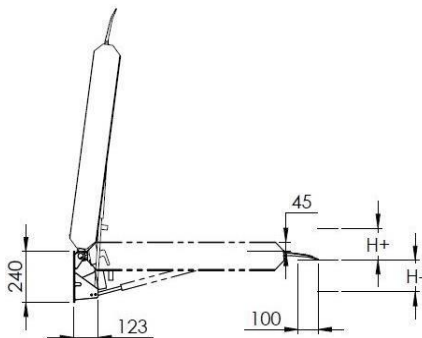
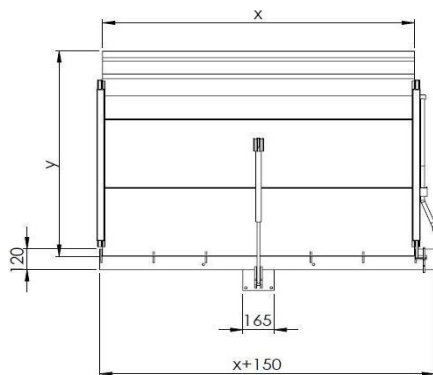

TECHNICAL DETAILS

NOMINAL LENGTH*	800/1060/1200/1600/2000 mm
NOMINAL WIDTH*	1650/2000 mm
CAPACITY	40 kN (4T) – CR-GAS80B 50 kN standard 60 kN ON REQUEST
PLATE+LIP	H40mm aluminium extruded profiles
MAX. CONCENTRATED LOAD ON PLATFORM	1,3 N/mm ²
ACTIVATION	Rigid side handle Gas strut servo-assistance
SAFETY	Anti-falling Pedal mechanic sideblock

CODE	CAPACITY (kg)	X mm	Y mm	H+/-	WEIGHT (Kg)
CR-GAS80B	4000	2000	800	100	60
CR-GAS106B	5000	2000	1060	130	65
CR-GAS120A	5000	1650	1200	150	70
CR-GAS160A	5000	1650	1600	200	90
CR-GAS200A	5000	1650	2000	250	110
CR-GAS120B	5000	2000	1200	150	90
CR-GAS160B	5000	2000	1600	200	105
CR-GAS200B	5000	2000	2000	250	125

FIXED MANUAL RAMP ACCESSORIES

WALL SCREWING ANGULAR PROFILE L150.250.2500-5

Wall screwing 150x250mm angular profile with 5mm thickness and 2500mm length is **necessary for installation of manual fixed ramps or miniramps to loading bay corners with NO METAL PROFILE OR TOO LITTLE PROFILE OR DAMAGED PROFILE for fixing.**

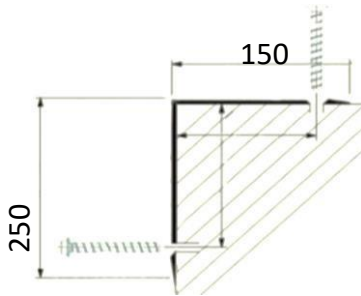

LENGTH 2500MM

EXT Protection and distancing side structures (CR-GAS)

Protection and distancing side structures type EXT, made of GALVANIZED STEEL PROFILES with variable width (see images below), can ensure **FASTER AND SAFER TRUCK PARKING**, as they can let vehicle stay at the right position to lay down the lip onto the truckfloor



EXT
120MM



EXT2
240MM

Side protection handrails for EXT structures (CR-GAS)

PPT galvanized steel side protection handrails, with H1100mm and h100mm TOEBOARD, combined with side protection EXT structures, can prevent from any side falling danger on CR-GAS ramp

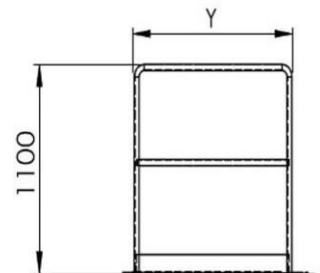

Y --> L EXT

SLIDING MANUAL RAMP ACCESSORIES: SLIDING RAILS

GF GALVANIZED STEEL RAILS TO BE WELDED TO PRE-EXISTING PROFILE

Galvanized steel rails are engineered to be directly SCREWED TO AN EXISTING H160MM PROFILE WITH TANGS INSIDE CONCRETE, not included in supply and to be previously cast inside concrete during building operations.

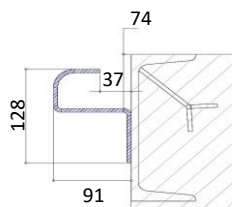

TR.GF3000
FOR TR/TRR

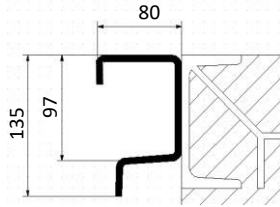

GAS.GF3000
FOR GAS/ES

GA ALUMINUM ANGULAR RAILS TO BE SCREWED TO CONCRETE

Aluminum angular rails can be directly LAID AND SCREWED ONTO CONCRETE CORNERS (WITH SCREWS INCLUDED IN SUPPLY), they're the perfect choice in case of absence of metal profiles or in case they were too small for the steel rails.

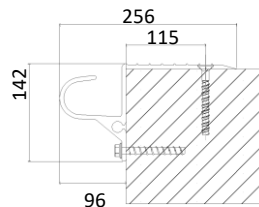

TR.GA3000
FOR TR/TRR

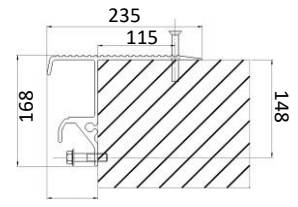

76
GAS.GA3000
FOR GAS/