

10. CR-GAS

Aluminum manual ramp with gas spring assistance. The ramp cannot slide, it has a steel hinge joint to be welded to the bay. It can be positioned through a rigid steel handrail

HYDRAULIC LIFTING SYSTEM MODIFY AVAILABLE ON REQUEST

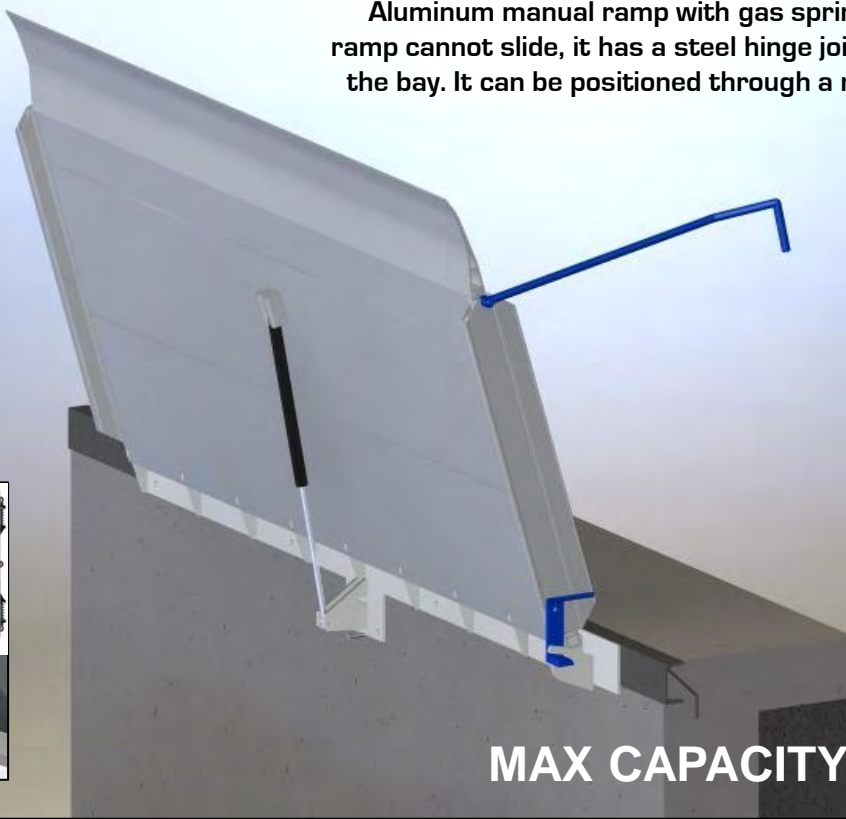

MAX CAPACITY 5000 KG

DETAILS:

- Aluminum plate in 6060 extruded with 5000kg maximum capacity
- Surface treatment with anti-slip cross-ribbing
- Positioning system through rolling on hinge joint with weldable backplate
- Control device: rigid steel handle (**blue coloured**)
- Automatic safety antifalling device (**blue coloured**)
- Gas spring for positioning assistance

OPTIONAL: L shape aluminum plate for installation without welding, through screws.

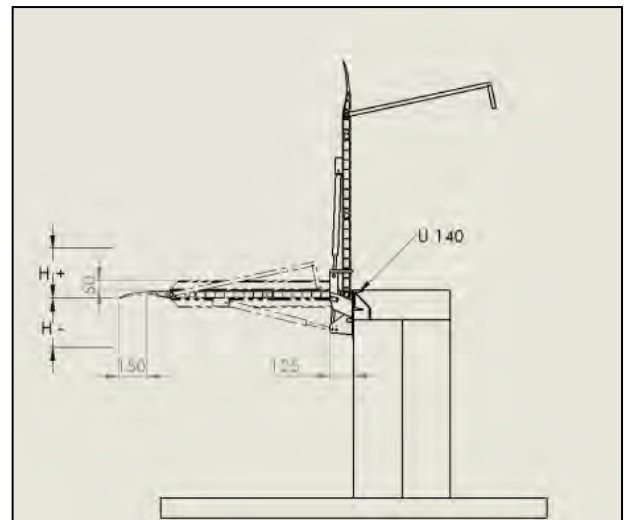

CODE	X	Y	WEIGHT	H+ / H-
	(mm)	(mm)	(Kg)	(mm)
CR-GAS120A	1650	1200	70	150/150
CR-GAS160A	1650	1600	90	200/200
CR-GAS200A	1650	2000	110	250/250
CR-GAS120B	2000	1200	90	150/150
CR-GAS160B	2000	1600	105	200/200
CR-GAS200B	2000	2000	125	250/250

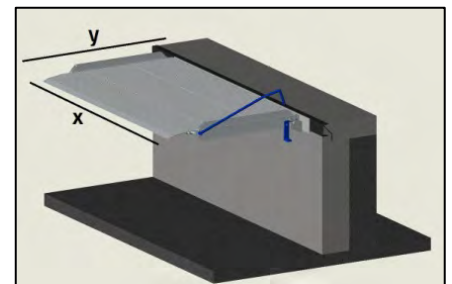

H+/- difference in height calculated according to UNI EN 1398 standard for 12,5% gradient allowed for forklifts