

DELTA TP AC-evo

Skids, Ramps and Double-Pallet Handling

Capacity (kg): 1200 - 1500 Lifting Height (mm): 1600, 2500, 3000, 3500

DELTA TP AC-evo

With a built-in leg lift, the DELTA TP is the perfect solution to handle loads in places where you need to pass over ramps, skids, small obstacles and floor irregularities.



Handles two loads simultaneously, one on the forks and the second on the legs.



AC technology
+ Performance
+ Driving control
- Service Costs

FULLY POWERED STACKERS

Feature in details:



LEGS LIFTING:

A hydraulic lift adjusts the height of the supporting legs, increasing the clearance between the floor and machine base, enabling the stacker to safely operate on ramps and slopes while simultaneously handling two loads.

4 VIE AC-evo

4 Directions of travel

Capacity (kg): 1200 - 1500 - 2000 Lifting Height (mm): 1600, 2500, 3000, 3500

4 VIE AC-evo

Movement in 4 directions solves the problems associated with handling wide loads such as bars and pipes in confined spaces and narrow aisles.



Lateral movement left or right



Movement forward and reverse

AC technology
+ Performance
+ Driving control
- Service Costs



FULLY POWERED STACKERS

Features in detail:



DIRECTION VARIATION:

A hydraulic control rotates the orientation of the wheels by 90° with respect to the forks, thus varying the direction of travel forward and reverse or left and right to handle bulky loads and navigate in confined spaces.



DELTA TP AC-evo

| model | | 125/16 | 155/16 | 125/25 | 155/25 | 125/30 | 155/30 | 125/35 | 155/35 |
|-------|----|--------|--------|--------|--------|--------|--------|--------|--------|
| Q | Kg | 1200 | 1500 | 1200 | 1500 | 1200 | 1500 | 1200 | 1500 |
| C | mm | 600 | 600 | 600 | 600 | 600 | 600 | 600 | 600 |
| I | mm | 1150 | 1150 | 1150 | 1150 | 1150 | 1150 | 1150 | 1150 |
| L | mm | 2025 | 2045 | 2060 | 2080 | 2060 | 2080 | 2060 | 2080 |
| X | mm | 275 | 275 | 310 | 310 | 310 | 310 | 310 | 310 |
| X2 | mm | 175 | 175 | 175 | 175 | 175 | 175 | 175 | 175 |
| Y | mm | 1575 | 1595 | 1575 | 1595 | 1575 | 1595 | 1575 | 1595 |
| L2 | mm | 885 | 905 | 920 | 940 | 920 | 940 | 920 | 940 |
| M | mm | 560 | 560 | 560 | 560 | 560 | 560 | 560 | 560 |
| N | mm | 180 | 180 | 180 | 180 | 180 | 180 | 180 | 180 |
| h1 | mm | 1990 | 1990 | 1740 | 1740 | 1990 | 1990 | 2250 | 2250 |
| h2 | mm | 1450 | 1450 | 200 | 200 | 200 | 200 | / | / |
| h3 | mm | 1600 | 1600 | 2500 | 2500 | 3000 | 3000 | 3500 | 3500 |
| h4 | mm | 2120 | 2120 | 3020 | 3020 | 3520 | 3520 | 4020 | 4020 |
| B | mm | 840 | 840 | 840 | 840 | 840 | 840 | 1000 | 1000 |
| WA | mm | 1770 | 1790 | 1770 | 1790 | 1770 | 1790 | 1770 | 1790 |

STANDARD EQUIPMENT

- AC three-phase technology traction motors • Electronic plant 24V with controller with mosfet technology complete with inverter and microprocessor fault research • Regenerative braking with consumption reduction and temperature control of the traction motor • Free lift 200 mm (excluded lifting height mm 3500) • Built-in electronic battery charger 24V 30A with microprocessor • Forks control by hydraulic distributor • Support legs lift by hydraulic distributor • Fixed forks length mm 1150 • Electric end stroke • Parking Brake • Shock absorber on driving-wheel • Side wheels with extra-heavy castors • Exhausted battery warning-indicator • DR-EVO Steering • Automatic speed reduction • Safety components • Traction Battery 24V from 160 to 270 Ah

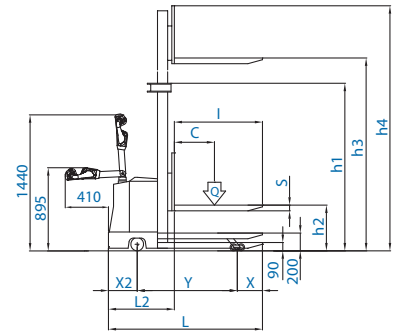
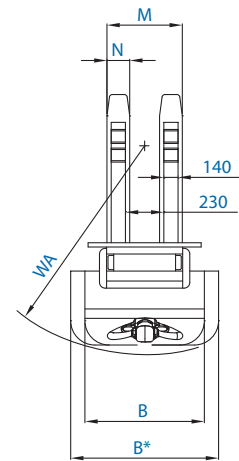

4 VIE AC-evo

| model | | 125/16 | 155/16 | 200/16 | 125/25 | 155/25 | 200/125 | 125/30 | 155/30 | 200/30 | 125/35 | 155/35 | 200/35 |
|-------|----|----------|----------|----------|----------|----------|----------|----------|----------|----------|----------|----------|----------|
| Q | Kg | 1200 | 1500 | 2000 | 1200 | 1500 | 2000 | 1200 | 1500 | 2000 | 1200 | 1500 | 2000 |
| C | mm | 450 | 450 | 600 | 450 | 450 | 600 | 450 | 450 | 600 | 450 | 450 | 600 |
| I | mm | 950 | 950 | 1150 | 950 | 950 | 1150 | 950 | 950 | 1150 | 950 | 950 | 1150 |
| L | mm | 1780 | 1780 | 1805 | 1810 | 1810 | 1835 | 1810 | 1810 | 1835 | 1810 | 1810 | 1835 |
| X | mm | 310 | 310 | 310 | 330 | 330 | 330 | 330 | 330 | 330 | 330 | 330 | 330 |
| X2 | mm | 175 | 175 | 175 | 175 | 175 | 175 | 175 | 175 | 175 | 175 | 175 | 175 |
| Y | mm | 1285 | 1285 | 1285 | 1305 | 1305 | 1305 | 1305 | 1305 | 1305 | 1305 | 1305 | 1305 |
| L2 | mm | 840 | 840 | 865 | 860 | 860 | 885 | 860 | 860 | 885 | 860 | 860 | 885 |
| M | mm | 350/1300 | 350/1300 | 350/1300 | 350/1300 | 350/1300 | 350/1300 | 350/1300 | 350/1300 | 350/1300 | 350/1300 | 350/1300 | 350/1300 |
| N | mm | 160 | 160 | 160 | 160 | 160 | 160 | 160 | 160 | 160 | 160 | 160 | 160 |
| h1 | mm | 1990 | 1990 | 1990 | 1740 | 1740 | 1740 | 1990 | 1990 | 1990 | 2250 | 2250 | 2250 |
| h2 | mm | 1450 | 1450 | 1450 | 200 | 200 | 200 | 200 | 200 | 200 | / | / | - |
| h3 | mm | 1600 | 1600 | 1600 | 2500 | 2500 | 2500 | 3000 | 3000 | 3000 | 3500 | 3500 | 3500 |
| h4 | mm | 2070 | 2070 | 2070 | 2970 | 2970 | 2970 | 3470 | 3470 | 3470 | 3970 | 3970 | 3970 |
| B | mm | 1620 | 1620 | 1620 | 1620 | 1620 | 1620 | 1620 | 1620 | 1620 | 1620 | 1620 | 1620 |
| WA | mm | 1510 | 1510 | 1510 | 1510 | 1510 | 1510 | 1510 | 1510 | 1510 | 1510 | 1510 | 1510 |

STANDARD EQUIPMENT

- AC three-phase technology traction motors • Electronic plant 24V with controller with mosfet technology complete with inverter and microprocessor fault research • Regenerative braking with consumption reduction and temperature control of the traction motor • Free lift 200 mm (excluded lifting height mm. 3500) • Extruded mast with lateral contrast bearings • Built-in electronic battery charger 24V 30A with microprocessor • Forks control by hydraulic distributor • Hydraulic directional front-wheel • Adjustable forks length mm 950 • Electric end stroke • Parking Brake • Shock absorber on driving-wheel • Side wheels with extra-heavy castors • Exhausted battery warning-indicator • DR-EVO Steering • Automatic speed reduction • Safety components • Traction Battery 24V from 160 to 270 Ah

