

17. PLUS

PERFECT FOR

- [Loading on variable height vehicles and sometimes very high gradients](#) (loading on containers) or [loading on stationary truck-backs](#) (trucks have different heights and truck-backs are left at different distances)
- [Loading on no fix bay](#) (the bay has to be used after loading for other purposes)

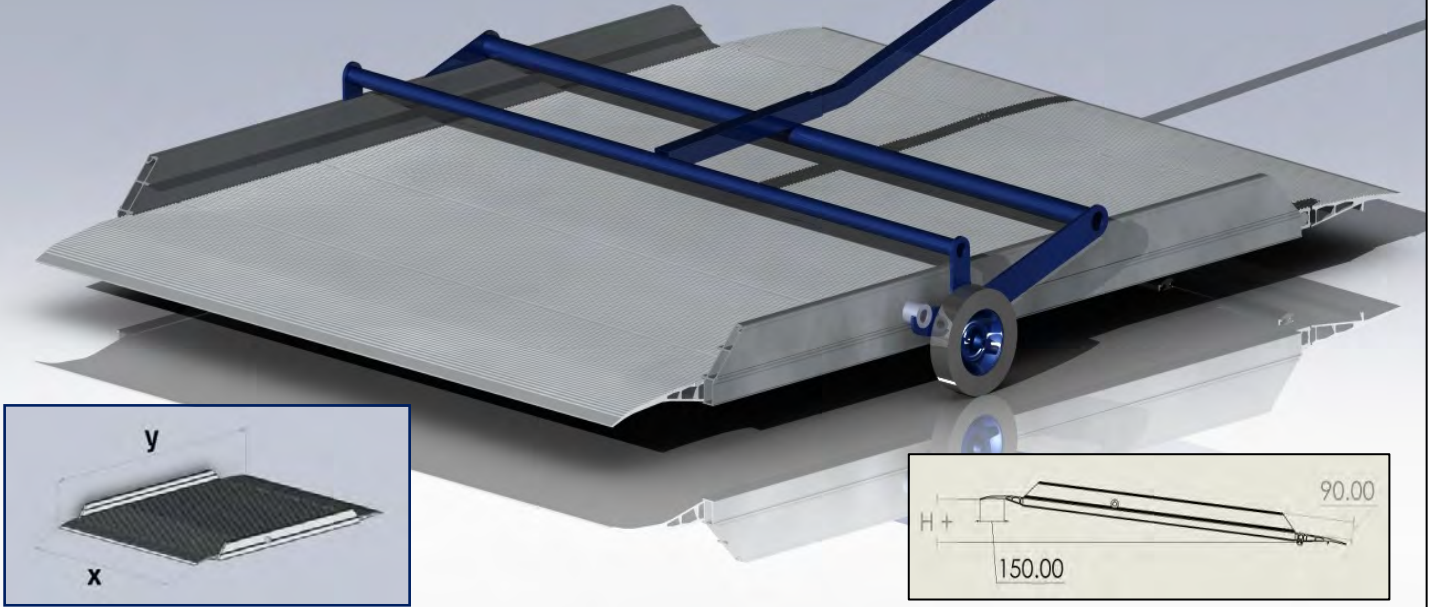

DETAILS:

- Aluminum 6060 alloy extruded profile with 6000kg capacity
- Hinged Back-lip for perfect fitting in loading surface
- gummy antislip seal to groundfloor mounted on backflip

CAPACITY 6000 KG

CODE	X	Y	WEIGHT	H+
	(mm)	(mm)	(Kg)	(mm)
PLUS150A	1650	1200*	100	200
PLUS190A	1650	1600*	120	250
PLUS230A	1650	2000*	140	300
PLUS150B	2000	1200*	125	200
PLUS190B	2000	1600*	150	250
PLUS230B	2000	2000*	180	300

RUBBER ANTISLIP SEALS INCLUDED

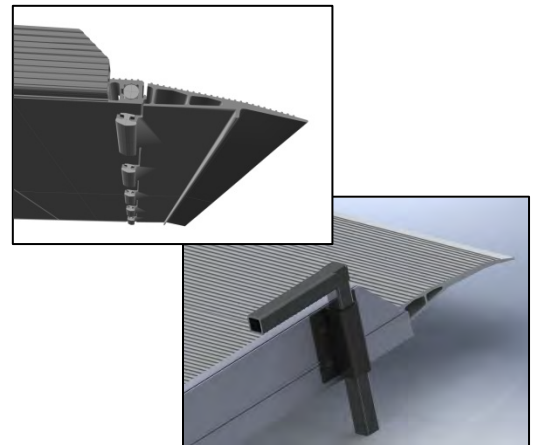

* Y factor DOES NOT include 300 mm hinged connection lip
 H+/- difference in height calculated according to
 UNI EN 1398 standard for 12,5% max gradient allowed for loading ramps

LATERAL SAFETY BLOCKS OPTIONAL

FOR FORKLIFT POSITIONING

CAR-MU1650
 CAR-MU2000



TROLLEYS

FOR MANUAL POSITIONING

CAR-MA1650
 CAR-MA2000

